

Thumbwheel Switch Temperature Controllers



T3 / T4 Series PRODUCT MANUAL

For your safety, read and follow the considerations written in the instruction manual, other manuals and Autonics website.

The specifications, dimensions, etc are subject to change without notice for product improvement. Some models may be discontinued without notice.

Features

- Various control output options : relay, SSR drive, current
- 2 independent set points and control outputs for heating and cooling control (T4LP)
- Various sizes (W48×H48, W48×H96, W72×H72, W96×H96 mm)

Safety Considerations

- Observe all 'Safety Considerations' for safe and proper operation to avoid hazards.
- ⚠ symbol indicates caution due to special circumstances in which hazards may occur.

⚠ Warning Failure to follow instructions may result in serious injury or death

- 01. Fail-safe device must be installed when using the unit with machinery that may cause serious injury or substantial economic loss.** (e.g. nuclear power control, medical equipment, ships, vehicles, railways, aircraft, combustion apparatus, safety equipment, crime/disaster prevention devices, etc.)
Failure to follow this instruction may result in personal injury, economic loss or fire.
- 02. Do not use the unit in the place where flammable/explosive/corrosive gas, high humidity, direct sunlight, radiant heat, vibration, impact or salinity may be present.**
Failure to follow this instruction may result in explosion or fire.
- 03. Install on a device panel to use.**
Failure to follow this instruction may result in electric shock.
- 04. Do not connect, repair, or inspect the unit while connected to a power source.**
Failure to follow this instruction may result in fire or electric shock.
- 05. Check 'Connections' before wiring.**
Failure to follow this instruction may result in fire.
- 06. Do not disassemble or modify the unit.**
Failure to follow this instruction may result in fire or electric shock.

⚠ Caution Failure to follow instructions may result in injury or product damage

- 01. When connecting the power input and relay output, use AWG 20 (0.50 mm²) cable or over, and tighten the terminal screw with a tightening torque of 1.0 N m.**
When connecting the sensor input and communication cable without dedicated cable, use AWG 28 to 16 cable and tighten the terminal screw with a tightening torque of 1.0 N m.
Failure to follow this instruction may result in fire or malfunction due to contact failure.
- 02. Use the unit within the rated specifications.**
Failure to follow this instruction may result in fire or product damage
- 03. Use a dry cloth to clean the unit, and do not use water or organic solvent.**
Failure to follow this instruction may result in fire or electric shock.
- 04. Keep the product away from metal chip, dust, and wire residue which flow into the unit.**
Failure to follow this instruction may result in fire or product damage.

Cautions during Use

- Follow instructions in 'Cautions during Use'. Otherwise, it may cause unexpected accidents.
- Check the polarity of the terminals before wiring the temperature sensor. For RTD temperature sensor, wire it as 3-wire type, using cables in same thickness and length. For thermocouple (TC) temperature sensor, use the designated compensation wire for extending wire.
- Keep away from high voltage lines or power lines to prevent inductive noise. In case installing power line and input signal line closely, use line filter or varistor at power line and shielded wire at input signal line. Do not use near the equipment which generates strong magnetic force or high frequency noise.

- Install a power switch or circuit breaker in the easily accessible place for supplying or disconnecting the power.
- Do not use the unit for other purpose (e.g. voltmeter, ammeter), but temperature controller.
- Make a required space around the unit for radiation of heat. For accurate temperature measurement, warm up the unit over 20 min after turning on the power.
- Install a surge absorber at each end of inductive load coil when controlling high-capacity power relay or inductive load (e.g. magnet).
- Make sure that power supply voltage reaches to the rated voltage within 2 sec after supplying power.
- Do not wire to terminals which are not used.
- This unit may be used in the following environments.
 - Indoors (in the environment condition rated in 'Specifications')
 - Altitude Max. 2,000 m
 - Pollution degree 2
 - Installation category II

Ordering Information

This is only for reference, the actual product does not support all combinations. For selecting the specified model, follow the Autonics website.

T **1** **2** **3** - **4** **5** **6** **7** **8** - **9**

1 Digit

3: 3 digit
4: 4 digit

2 Size

S: DIN W 48 × H 48 mm (8 pin plug type)
M: DIN W 72 × H 72 mm
H: DIN W 48 × H 96 mm
L: DIN W 96 × H 96 mm

3 Option output

PN	Option output	T3S	T3H	T4M	T4L
No mark	No output	○	○	○	○
A	Alarm	-	○	○	○
S	Option	-	○	-	-
P	Dual setting	-	-	-	○

4 Control method

B: ON/OFF / Proportional

5 Power supply

4: 100-240 VAC 50/60Hz

6 Control output

R: Relay
S: SSR drive
C: Current

7 Input type and using range

PN	Input type	Using range	T3S	T3H	T3HA	T3HS	T4M T4MA	T4L T4LA	T4LP
K4	Thermocouple K(CA)	0 to 400 °C	○	○	○	○	○	○	○
K8		0 to 800 °C	○	○	○	-	○	○	○
KA		0 to 999 °C	-	○	○	-	-	-	-
KC		0 to 1200 °C	-	-	-	-	○	○	○
J2	J(IC)	0 to 200 °C	○	-	-	-	-	-	-
J4		0 to 400 °C	○	○	○	○	○	○	○
J8		0 to 800 °F	-	○	-	-	-	-	-
RF	R(PR)	600 to 1600 °C	-	-	-	-	○	○	○
P0	RTD 100Ω DPt	-99.9 to 199.9 °C	-	-	-	-	○	○	-
P0		-99 to 199 °C	-	○	○	-	-	-	-
P1		0 to 99.9 °C	○	○	-	-	-	-	-
P2		0 to 200.0 °C	-	-	-	-	-	-	○
P2	RTD 100Ω DPt	0 to 200 °C	○	-	-	-	-	-	-
P4		0 to 400 °C	○	○	○	○	○	○	○

8 Temperature unit

C: Celsius (°C)
F: Fahrenheit (°F)

- Contact us for temperature unit °F model.

9 Version

N: New

Product Components

- Product (+ bracket)
- Instruction manual

Sold Separately

- 8-pin controller socket: PG-8, PS-8 (N)
- Terminal protection cover: RMA / RHA / RLA-COVER

Specifications

Series		T3, T4 Series
Power supply		100 - 240 VAC ~ 50/60 Hz
Permissible voltage range		90 to 110 % of rated voltage
Power consumption		≤ 5 VA
Sampling period		100 ms
Input specification		Refer to 'Ordering Information: Input type and using range'.
Display accuracy ⁰¹⁾		<ul style="list-style-type: none"> • At room temperature (23 °C ± 5 °C): (PV ± 0.5% or ± 1°C higher one) ± 1 digit • Out of room temperature range: (PV ± 0.5% or ± 2 °C higher one) ± 1 digit
Control output	Relay ⁰²⁾	OUT1: 250 VAC ~ 5 A / 30 VDC = 5A 1c, OUT2: 250 VAC ~ 2 A / 30 VDC = 2A 1c
	SSR	12 VDC = ± 2 V, ≤ 20 mA
	Current	DC 4-20 mA, Load resistance: ≤ 500 Ω
Option output		250 VAC ~ 2 A 1c
Alarm output setting range		F.S. 0 to 10% (volume switch)
Option output setting range		0 to 50 °C (volume switch)
Reset range		F.S. -3 to 3% (volume switch)
Display type		7 segment (red), LED type
Control type		ON/OFF, Proportional control
Hysteresis		F.S. 0.2 to 3% (T3S: F.S. 0.5%) (volume switch)
Proportional band		F.S. 1 to 10% (T3S: F.S. 3%) (volume switch)
Proportional cycle		20 sec
Relay life cycle	Mechanical	≥ 5,000,000 operations
	Electrical	OUT1: ≥ 100,000 operations, OUT2: ≥ 200,000 operations
Dielectric strength		Between the charging part and the case: 2,000 VAC ~ 50/60 Hz for 1 min
Vibration		0.75 mm amplitude at frequency of 10 to 55 Hz in each X, Y, Z direction for 2 hours
Insulation resistance		≥ 100 MΩ (500 VDC = megger)
Noise immunity		± 2 kV square shaped noise by noise simulator (pulse width 1 μs) R-phase, S-phase
Memory retention		≈ 10 years (non-volatile semiconductor memory type)
Ambient temperature		-10 to 50 °C, storage: -20 to 60 °C (no freezing or condensation)
Ambient humidity		35 to 85%RH, storage: 35 to 85%RH (no freezing or condensation)
Certification ⁰³⁾		ERC
Unit weight (packaged)		<ul style="list-style-type: none"> • T3S: ≈ 95 g (≈ 135 g) • T3H, T3HA, T3HS: ≈ 176 g (≈ 239 g) • T4M, T4MA: ≈ 180 g • T4L, T4LA, T4LP: ≈ 222 g (≈ 310 g) (≈ 246 g)

01) In case of the T3S Series and the decimal point display models
At room temperature (23 °C ± 5 °C): (PV ± 0.5% or ± 2 °C higher one) ± 1 digit
Out of room temperature range: (PV ± 0.5% or ± 3 °C higher one) ± 1 digit

02) Dual setting output of the T4LP is fixed as relay output and, it is also available as alarm output.

03) Certification attainment may vary depending on the model. Check the certification on the Autonics website.

Unit Descriptions

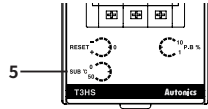
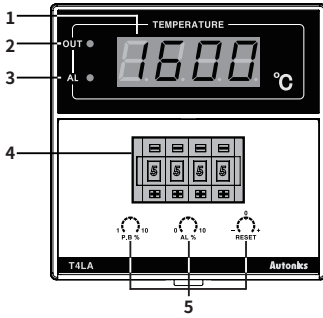

1. PV (Present value) display part (Red)

2. Control output (OUT) Indicator

- Turns ON when control output is ON.
- In case of the T3S, the upper DOT of last digit flashes.

3. Alarm/Option output (AL / SUB) Indicator

- Turns ON when alarm/option output is ON.
- (only for alarm output model)

4. SV (Setting value) thumbwheel switch

- [-]: Decreases number, [+]: Increases number
- The models which temperature range is 0 (-99.9 to 199.9°C, -99 to 199°C) of temperature sensor DPt100Ω are only set 1 ↔ 0 ↔ (-).
- The dual setting output model (T4LP) has two thumbwheel switches.

5. Volume switch

Display	Name	Description
P.B %	Hysteresis / Proportional band	ON/OFF control: Setting for hysteresis Proportional control: Setting for proportional band • Except T3S
AL %	Alarm output	Setting for alarm output
RESET	Reset	In case of proportional control, it sets offset.
SUB	Option output SV	Setting for deviation low limit alarm temperature

LO SET



Low set output:
Heating control

HI SET

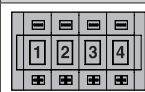

High set output:
Cooling control

Connections

T3S

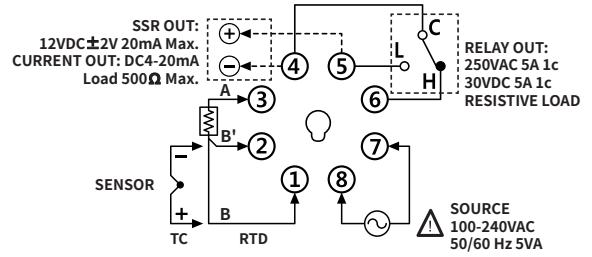

T4M/T4MA

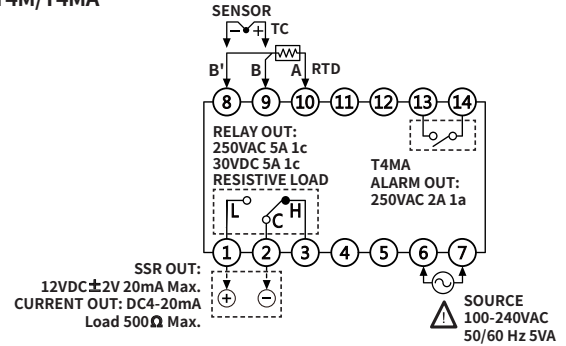

T3H/T3HA/T3HS

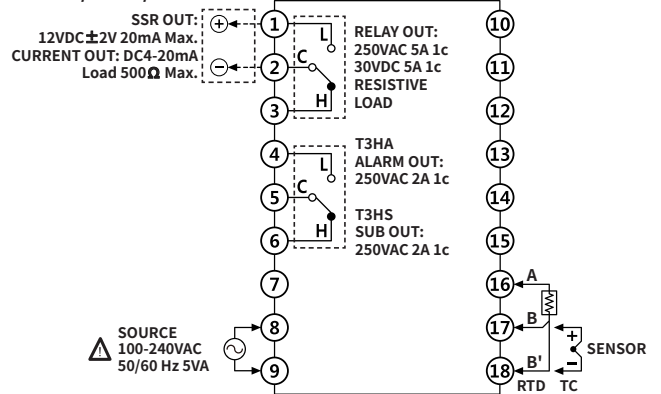

T4L/T4LA/T4LP

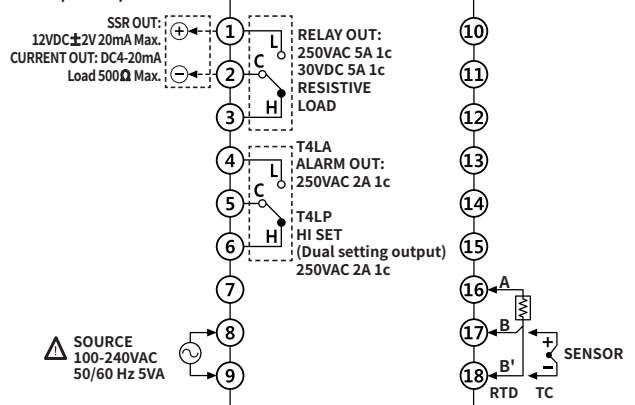

Crimp Terminal Specifications

- Unit: mm, Use the crimp terminal of follow shape.



Fork crimp terminal

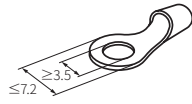

Round crimp terminal

Dimensions

- Unit: mm, For the detailed drawings, follow the Autonics website.
- Below is based on T3S Series.

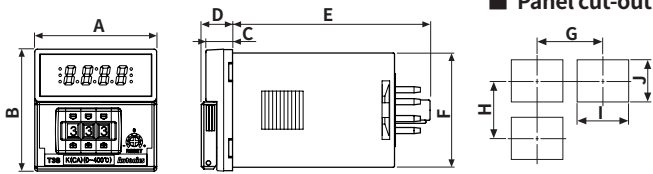

Panel cut-out

	Body					Panel cut-out				
	A	B	C	D	E	F	G	H	I	J
T3S	48	48	10.5	12.3	77.8	□45	≥ 65	≥ 65	45 ^{+0.6} ₀	45 ^{+0.6} ₀
T3H	48	96	13	-	70	91.5	≥ 65	≥ 115	45 ^{+0.6} ₀	92 ^{+0.8} ₀
T4M	72	72	11.8	14.3	75	□67.5	≥ 90	≥ 90	68 ^{+0.7} ₀	68 ^{+0.7} ₀
T4L	96	96	12.5	-	70	□91.5	≥ 115	≥ 115	92 ^{+0.8} ₀	92 ^{+0.8} ₀

Bracket

T3S

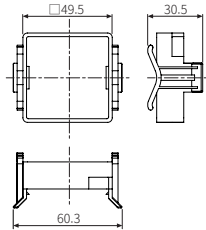

Other series

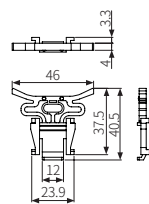

Control Type Setting

Before supplying power, detach the case and set the control method by the control type setting switch.

Detaching the case

T3S	Other series
<p>Press the 8-pin plug with your thumb. Insert a flat head driver to the groove (①) and uplift the case (same as the other side). Push it to the ② direction and the case is removed.</p>	<p>Press the peaks (①) on both side with your thumb. Pull the case to the ② direction and it is removed.</p>

Control type setting switch

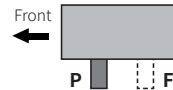

P: Proportional control (default)
F: ON/OFF control

Initial Display When Power is ON

When power is supplied, whole display parts turn ON for 1 sec. After displaying model type, it returns to RUN mode.

- During displaying model type, control output does not operate.

1. All display	2. Digit, alarm/ option output	3. Control output, input type and using range	4. RUN mode
8.8.8.8	ε 35	r P 4 C	200

Errors

Display	Description	Output				Troubleshooting
		Control ⁰¹⁾	Alarm	Option	Dual setting	
a P E n	Flashes when input sensor is disconnected or sensor is not connected.	OFF	ON	OFF	ON	Check input sensor status.
H H H H	Flashes when PV is higher than using range. ⁰²⁾	OFF	ON	OFF	ON	When input is within the rated using range, this display disappears.
L L L L	Flashes when PV is lower than using range. ⁰²⁾	ON	ON	ON	OFF	When input is within the rated using range, this display disappears.
S w E r	SV, ER and PV are cross flashed when SV is out of using range • When error and the others occur at the same time, they are crossed flashed.	OFF	OFF	OFF	OFF	Set SV in using range.

01) In case of T4LP (Dual setting output), it is adapted to the single output.

02) Be careful that when H H H H / L L L L error occurs, the control output may occur by recognizing the maximum or minimum input depending on the control type.

[T3HS Series] Function: Option Output

This output operates as deviation low-limit alarm. (Hysteresis: 2°C, fixed)

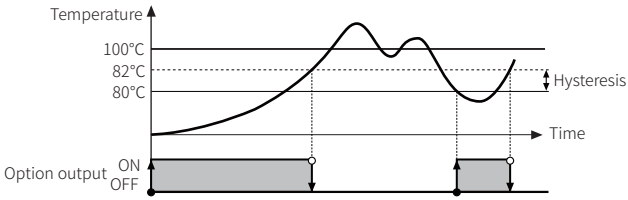

[T4LP Series] Function: Dual Setting Output

- LO SET (low set output): ON/OFF control, proportional control
- HI SET (high set output): Absolute value high-limit alarm output (Hysteresis: 2°C fixed)

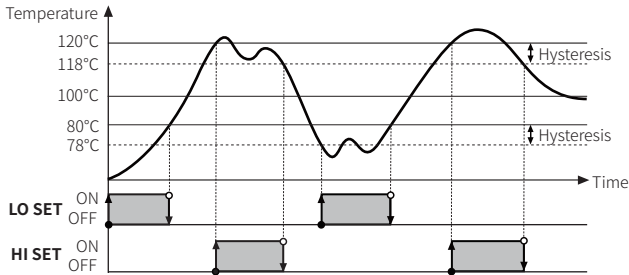

Sold Separately: 8-pin Controller Socket

• For detailed information, refer to the 'PG Series, PS Series' manual.

Appearance	Pins	Rated Voltage	Rated current	Feature	Model
	8-pin	250 VAC~	7 A (resistance load)	Controller socket	PG-08
	8-pin	250 VAC~	7 A (resistance load)	Controller socket (DIN Rail / Panel)	PS-08(N)

Sold Separately: Terminal Protection Cover

• Unit: mm

RMA-COVER: DIN W72 × H72

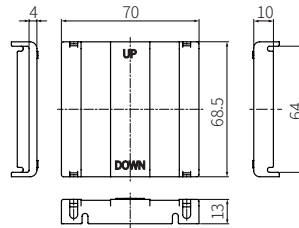

RHA-COVER: DIN W48 × H96

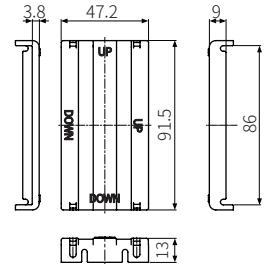

RLA-COVER: DIN W96 × H96

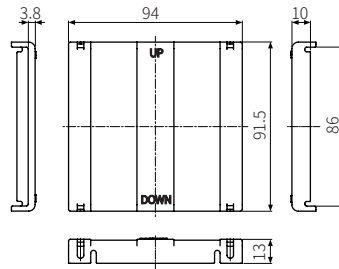

Segment Table

The segments displayed on the product indicate the following meanings. It may differ depending on the product.

7 Segment	11 Segment	12 Segment	16 Segment
0	0	0	0
1	1	1	1
2	2	2	2
3	3	3	3
4	4	4	4
5	5	5	5
6	6	6	6
7	7	7	7
8	8	8	8
9	9	9	9
A	A	A	A
b	b	b	b
c	c	c	c
d	d	d	d
E	E	E	E
F	F	F	F
G	G	G	G
H	H	H	H