





# Ø 22/25 mm, Ø 30 mm, □ 30 mm Control Switches Accessories

Contact Blocks (SA□ -C□ □)				
Model	Contact	Features	Applied switches	Appearance
SA-CAM	A contact (normally open)	<ul style="list-style-type: none"> <li>Modular type</li> <li>Ring / Fork terminal available</li> <li>Modular connection (up to 3 units)</li> </ul>	Ø 22/25 mm, Ø 30 mm, □ 30 mm Control switches	
SA-CBM	B contact (normally closed)			
SA-CA	A contact (normally open)	<ul style="list-style-type: none"> <li>Singular type (dust-resistant contact point)</li> <li>Fork terminal available</li> <li>Loose screw prevention</li> </ul>		
SA-CB	B contact (normally closed)			



<b>Power supply / current</b>	110 VAC~ / 10 A, 250 VAC~ / 6 A
<b>Dielectric strength</b>	2,500 VAC~ 50/60 Hz for 1 minute
<b>Insulation resistance</b>	≥ 1,000 MΩ (500 VDC≡ megger)
<b>Contact resistance</b>	≤ 20 mΩ (initial)
<b>Electrical life cycle</b>	≥ 100,000 operations (20 operations/min)
<b>Contact material</b>	AgNi10
<b>Approval</b>	CE 
<b>Weight</b>	Modular type: ≈ 10 g, Singular type: ≈ 11 g

**■ Removal**

Separate the unit using a flat-head (-) screwdriver.

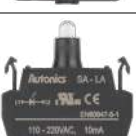

**LED Blocks (SA□ -L□ □)**

Model	Power supply	Features	Applied switches	Appearance
SA-LD□ M	AC/DC voltage type 12-24 VAC~ 50/60 Hz 12-24 VDC≡	<ul style="list-style-type: none"> <li>Modular type</li> <li>Ring / Fork terminal available</li> <li>Modular connection (up to 3 units)</li> </ul>	Ø 22/25 mm, Ø 30 mm, □ 30 mm Control switches, Pilot lights	
SA-LA□ M	AC voltage type 110-220 VAC~ 50/60 Hz			
SA-LD□	AC/DC voltage type 12-24 VAC~ 50/60 Hz 12-24 VDC≡	<ul style="list-style-type: none"> <li>Singular type (dust-resistant contact point)</li> <li>Fork terminal available</li> <li>Loose screw prevention</li> </ul>		
SA-LA□	AC voltage type 110-220 VAC~ 50/60 Hz			

□ : Color (R: Red / B: Blue / G: Green / Y: Yellow / W: White)

<b>Rated voltage</b>	AC/DC voltage type: 12-24 VAC~ 50/60 Hz, 12-24 VDC≡ AC voltage type: 110-220 VAC~ 50/60 Hz
<b>Current consumption</b>	≤ 20 mA
<b>Approval</b>	CE 
<b>Weight</b>	AC/DC voltage type: ≈ 11 g, AC voltage type: ≈ 12 g

**■ Removal**

Separate the unit using a flat-head (-) screwdriver. Same as contact removal method.

**Locking Handle (SA□ -LH)**





- For locking switch nuts behind the panels.

Model	Applied switches	Appearance
SA-LH	Ø 22/25 mm, Ø 30 mm, □ 30 mm Control switches, Pilot lights <sup>01)</sup>	

01) Except Ø 30 mm round pressure switches (extended).

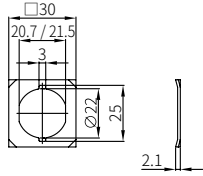
**Switch Washer (SA-SW□)**

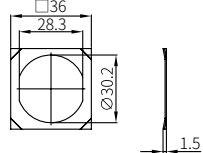
- The washer helps to improve switch tightening force.
- Unit: mm, For the detailed drawings, follow the Autonics web site.

Model	Applied switches	Dimensions	Appearance
SA-SW2	Ø 22/25 mm Control switches, Pilot lights		
SA-SW3	Ø 30 mm Control switches, Pilot lights		

## Switch Enclosures (SA-□ B□)

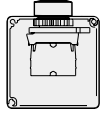
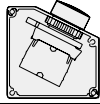
Model	Shape	Applied switches	Appearance
SA-SB□	Square	Ø 22/25 mm Control switches	
SA-TB□	Triangle		

□ : Number of holes (1 to 5)

You can order the other size and the number of holes.

### ■ Dimensions

Unit: mm, For the detailed drawings, follow the Autonics web site.

Model	Holes	L
SA-□ B1	1	86
SA-□ B2	2	136
SA-□ B3	3	186
SA-□ B4	4	236
SA-□ B5	5	286

SA-SB□

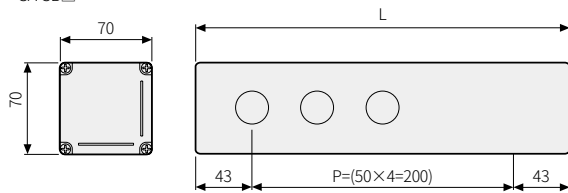



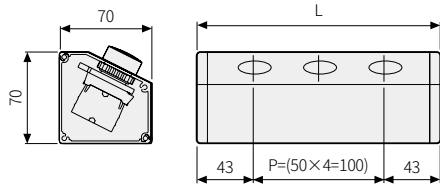

SA-TB□

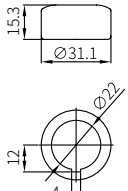

## Switch Waterproof Cap (SA-W□)

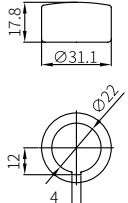
- IP65 protection structure with waterproof cap
- Unit: mm, For the detailed drawings, follow the Autonics web site.

Model	Applied switches	Dimensions	Appearance
SA-WP	Ø 22/25 mm Round non-illuminated / extended push button switches		
SA-WL	Ø 22/25 mm Round illuminated / extended push button switches		

## Emergency Switch Nameplates (SA-N□)

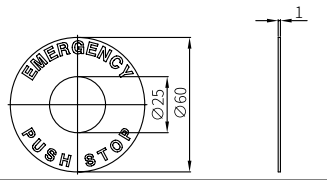
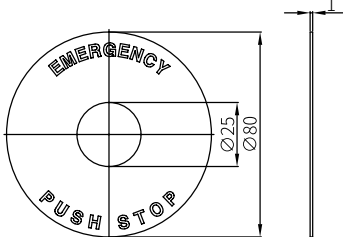

- Unit: mm, For the detailed drawings, follow the Autonics web site.
- Standard color is yellow. Luminous nameplates are optional.

Model	Applied switches	Appearance
SA-NS	Ø 22/25 mm Emergency switches (01)	<ul style="list-style-type: none"> <li>D60 × d25</li> </ul> 
SA-NL	Ø 22/25 mm Emergency switches	<ul style="list-style-type: none"> <li>D80 × d25</li> </ul> 

01) Except Ø 22/25 mm Emergency switch D60.

## Emergency Switch Protective Shrouds (SA-EG□)

- Protective shrouds to prevent accidental/incorrect operation.

Model	Applied switches	Appearance
SA-EG1	Ø 22/25 mm Emergency switches (01)	
SA-EG2 / SA-EG3		

01) Except Ø 22/25 mm Emergency switch D60.

### ■ Dimensions

- Unit: mm, For the detailed drawings, follow the Autonics web site.
- SA-EG1

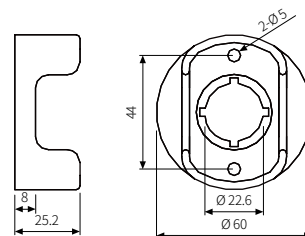

- SA-EG2 / EG3

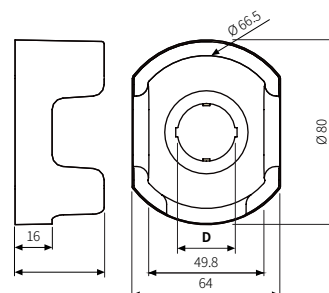

Model	D
SA-EG2	Ø 22.5
SA-EG3	Ø 25.5