

# 50 mm Wire-Type Linear Scale Absolute Encoders (Optical)

## EWLS50 Series

### INSTRUCTION MANUAL

TCD210037AC



Thank you for choosing our Autonics product.

**Read and understand the instruction manual and manual thoroughly before using the product.**

**For your safety, read and follow the below safety considerations before using.**

**For your safety, read and follow the considerations written in the instruction manual, other manuals and Autonics website.**

Keep this instruction manual in a place where you can find easily.

The specifications, dimensions, etc. are subject to change without notice for product improvement. Some models may be discontinued without notice.

Follow Autonics website for the latest information.

#### Safety Considerations

- Observe all 'Safety Considerations' for safe and proper operation to avoid hazards.
- ⚠ symbol indicates caution due to special circumstances in which hazards may occur.

**⚠ Warning** Failure to follow instructions may result in serious injury or death.

- Fail-safe device must be installed when using the unit with machinery that may cause serious injury or substantial economic loss. (e.g. nuclear power control, medical equipment, ships, vehicles, railways, aircraft, combustion apparatus, safety equipment, crime / disaster prevention devices, etc.)**  
Failure to follow this instruction may result in personal injury, economic loss or fire.
- Do not use the unit in the place where flammable / explosive / corrosive gas, high humidity, direct sunlight, radiant heat, vibration, impact or salinity may be present.**  
Failure to follow this instruction may result in explosion or fire.
- Install on a device panel to use.**  
Failure to follow this instruction may result in fire.
- Do not connect, repair, or inspect the unit while connected to a power source.**  
Failure to follow this instruction may result in fire.
- Check 'Connections' before wiring.**  
Failure to follow this instruction may result in fire.
- Do not disassemble or modify the unit.**  
Failure to follow this instruction may result in fire.

**⚠ Caution** Failure to follow instructions may result in injury or product damage.

- Use the unit within the rated specifications.**  
Failure to follow this instruction may result in fire or product damage.
- Do not short the load.**  
Failure to follow this instruction may result in fire.
- Do not use the unit near the place where there is the equipment which generates strong magnetic force or high frequency noise and strong alkaline, strong acidic exists.**  
Failure to follow this instruction may result in product damage.

#### Cautions during Use

- Follow instructions in 'Cautions during Use'. Otherwise, it may cause unexpected accidents.
- 12 - 24 VDC≐ power supply should be insulated and limited voltage / current or Class 2, SELV power supply device.
- Wire linear scale consists of encoder, spring, and wire. Be sure to install with care to prevent bad accuracy or breakdown due to taking down after drawing out, wounding, bending, or big impact to wire.  
Failure to follow this instruction may result in product damage or degradation of accuracy.
- While rewinding wire, it is possible to stop in the middle. Pull the wire out wire slowly and try to rewind again.
- For using the unit with the equipment which generates noise (switching regulator, inverter, servo motor, etc.), ground the shield wire to the F.G. terminal.
- Ground the shield wire to the F.G. terminal.
- When supplying power with SMPS, ground the F.G. terminal and connect the noise canceling capacitor between the 0 V and F.G. terminals.
- Wire as short as possible and keep away from high voltage lines or power lines, to prevent inductive noise.
- Check the wire type and response frequency when extending wire because of distortion of waveform or residual voltage increment etc. by line resistance or capacity between lines.
- This unit may be used in the following environments.
  - Indoors (in the environment condition rated in 'Specifications')
  - Altitude max. 2,000 m
  - Pollution degree 2
  - Installation category II

#### Cautions during Installation

- Install the unit correctly with the usage environment, location, and the designated specifications.
- Spring tension around 50 to 400 g·f is good for improving measuring repeat accuracy. Do not pull out the wire before installing the body.
- Measuring range setting should not be over max. measuring range of this product. It may cause wire break or bad accuracy due to over max. measuring range.
- Be careful not to enter water, oil, or dust caused bad accuracy of the body and wire.
- Do not wound the wire or pull-out max. wire length.  
It may cause bad accuracy because wire consists of nylon coated stainless steel wire.
- Do not apply tensile strength over 10 N to the cable.

#### Installation Method

- Install the body and pull-out wire direction in a straight line of measuring direction.
- Fix the wire hook to opposite side.  
For changing pull-out direction, a pully shall be used at the inflection point.
- Please designate either the product or the wire hook as fixed side, the other as moving side.

#### Ordering Information

This is only for reference, the actual product does not support all combinations. For selecting the specified model, follow the Autonics website.

EWLS50 - ① - ② - ③ - ④

- |  |   |
|--|---|
| ① <b>Measurement range</b><br>512: 512mm               | ③ <b>Control output</b><br>PN: Parallel NPN open collector output |
| ② <b>Output code</b><br>B: Binary code<br>G: Gray code | ④ <b>Power supply</b><br>24: 12 - 24 VDC ±5%                      |

#### Product Components

- Product
- Instruction manual
- Bolt × 2

#### Connections

- Unused wires must be insulated.
- The metal case and shield cable of encoders must be grounded (F.G.).
- F.G. (Frame Ground) must be grounded separately.

Color	Function	Refer
White	+V	Power
Black	GND	
Brown	2 <sup>0</sup>	
Red	2 <sup>1</sup>	
Orange	2 <sup>2</sup>	
Yellow	2 <sup>3</sup>	Data signal
Green	2 <sup>4</sup>	
Blue	2 <sup>5</sup>	
Purple	2 <sup>6</sup>	
Gray	2 <sup>7</sup>	
Pink	2 <sup>8</sup>	
Clear	2 <sup>9</sup>	
Light brown	2 <sup>10</sup>	
Light yellow	2 <sup>11</sup>	Overflow alarm (OVF)
Light green	2 <sup>12</sup>	
Light blue	Reset signal input	Signal shield
Shield	F.G.	

#### Inner Circuit

- The output circuit is identical for each output bit.
- Be aware of circuit break in case of overload or short beyond the specifications.

##### ■ Input

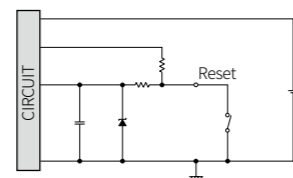

##### ■ Output

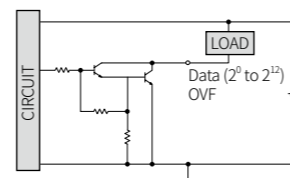

#### Output Waveform

- Following waveform is based on the positive logic. (In case of negative logic, the waveform is opposite to corresponding waveform.)

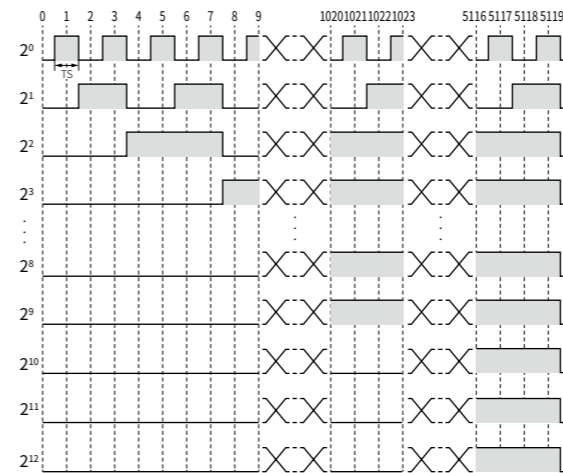

#### Specifications

Model	EWLS50-512-B-PN-24	EWLS50-512-G-PN-24
Measuring range	512 mm	
Max. output pulse	5,120 division / 512 mm	
Min. resolution	0.1 mm	
Accuracy	± 0.1 / 100 mm	
Response speed	≤ 500 mm / sec	
Wire movement limit when power is OFF <sup>(01)</sup>	≤ ± 20 mm	
Output code	Binary	Gray
Output signal	Data, Overflow alarm (OVF)	
Control output	Parallel NPN open collector output	
Inflow current	≤ 32 mA	
Residual voltage	≤ 1 VDC≐	
Output logic	Negative logic output	
Response speed <sup>(02)</sup>	≤ 1 μs	
Input signal	Reset signal input (Reset)	
Input level	H: 5 - 24 VDC≐, L: 0 - 1.2 VDC≐	
Input logic	Low Active, OPEN or HIGH for common use	
Input time	≥ 100 ms	
Max. response freq.	50 kHz	
Wire tensile force	0.5 to 4 N (50 to 400 g·f)	
Wire repeat life cycle	1,000,000 times	
Unit weight	≈ 450 g	
Approval	CE, EMC, RoHS	

<sup>(01)</sup> The product cannot process data when the power is Off. It calibrates the data comparing values of before and after power ON status. It shall be used on the condition that wire movement limit because proper data may not be available if any wire movement occurred over ±20mm from the position when power is off.

<sup>(02)</sup> Based on cable length: 2 m, I sink = 32 mA

Power supply	12 - 24 VDC≐ ± 5% (ripple P-P: ≤ 5%)
Current consumption	≤ 150 mA (no load)
Insulation resistance	≥ 100 MΩ (500 VDC≐ megger)
Dielectric strength	Between the charging part and the case: 750 VAC~ 50 / 60 Hz for 1 min.
Vibration	1 mm double amplitude at frequency 10 to 55 Hz in each X, Y, Z direction for 2 hours
Shock	≤ 50 G
Ambient temp.	-10 to 70 °C, storage: -25 to 85 °C (no freezing or condensation)
Ambient humi.	35 to 85%RH, storage: 35 to 90%RH (no freezing or condensation)
Connection	Axial cable type (cable gland)
Cable spec.	Ø 6 mm, 17-wire, 2 m, shield cable
Wire spec.	AWG28 (0.08 mm, 19-core), insulator diameter: Ø 0.8 mm
Material	Cap: SPCD, Body: A2024, Wire: SUS303

#### Dimensions

- Unit: mm, For the detailed drawings, follow the Autonics website.

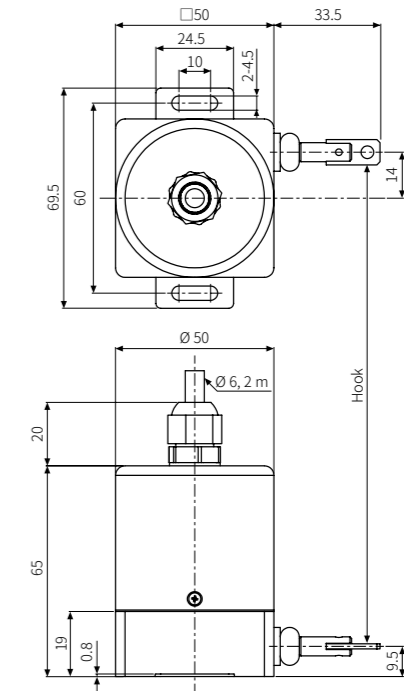

##### ■ Hook

