

# HART Protocol Transmitter

## KT-502H Series INSTRUCTION MANUAL

TCD210202AB



Thank you for choosing our Autonics product.

Read and understand the instruction manual and manual thoroughly before using the product.

For your safety, read and follow the below safety considerations before using.

For your safety, read and follow the considerations written in the instruction manual, other manuals and Autonics website.

Keep this instruction manual in a place where you can find easily.

The specifications, dimensions, etc. are subject to change without notice for product improvement. Some models may be discontinued without notice.

Follow Autonics website for the latest information.

### Safety Considerations

- Observe all 'Safety Considerations' for safe and proper operation to avoid hazards.
- ⚠ symbol indicates caution due to special circumstances in which hazards may occur.

**⚠ Warning** Failure to follow instructions may result in serious injury or death.

**01. Fail-safe device must be installed when using the unit with machinery that may cause serious injury or substantial economic loss.**(e.g. nuclear power control, medical equipment, ships, vehicles, railways, aircraft, combustion apparatus, safety equipment, crime/disaster prevention devices, etc.)  
Failure to follow this instruction may result in personal injury, economic loss or fire.

**02. Do not use the unit in the place where flammable/explosive gas, high humidity, direct sunlight, radiant heat, vibration, impact, or salinity may be present.**  
Failure to follow this instruction may result in explosion or fire.

**03. Do not connect, repair, or inspect the unit while connected to a power source.**  
Failure to follow this instruction may result in electric shock.

**04. For installing the unit, ground it exclusively and use over AWG11 (4 mm<sup>2</sup>) ground cable.**  
Failure to follow this instruction may result in electric shock.

**05. Do not disassemble or modify the unit.**  
Failure to follow this instruction may result in fire or electric shock.

**06. Check 'Connections' before wiring.**  
Failure to follow this instruction may result in fire.

**⚠ Caution** Failure to follow instructions may result in injury or product damage.

**01. Use the unit within the rated specifications.**  
Failure to follow this instruction may result in fire or product damage.

**02. Use a dry cloth to clean the unit, and do not use water or organic solvent.**  
Failure to follow this instruction may result in fire or electric shock.

**03. Keep the product away from metal chip, dust, and wire residue which flow into the unit.**  
Failure to follow this instruction may result in fire or product damage.

### Cautions during Use

- Follow instructions in 'Cautions during Use'. Otherwise, it may cause unexpected accidents.
- 10.5 - 45 VDC≐ Model power supply should be insulated and limited voltage/current or Class 2, SELV power supply device.
- Keep away from high voltage lines or power lines to prevent inductive noise. Do not use near the equipment which generates strong magnetic force or high frequency noise.
- Install a power switch or circuit breaker in the easily accessible place for supplying or disconnecting the power.
- The explosion-proof standard of this unit is Ex d IIC T6, protection structure of this unit is IP 67 and the range of max. surface temperature is below 85 °C. Use the verified explosion-proof electric connection (cable gland or sealing fitting)
- This unit may be used in the following environments.
  - Indoors (in the environment condition rated in 'Specifications')
  - Altitude max. 2,000 m
  - Pollution degree 2
  - Installation Category II
- The explosion-proof unit is certified and the same specifications which is reported to Korea Gas Safety Corporation. (This unit is manufactured following by the announcement 2013-54 of Ministry of Employment and Labor of Korea.)

### Ordering Information

This is only for reference, the actual product does not support all combinations. For selecting the specified model, follow the Autonics website.

**KT** - **502H** **1** - **2**

**1** Mounting bracket  
0: Without bracket  
1: With bracket

**2** Temperature input range  
Refer to 'Input Specifications'.

### Specifications

Model	KT-502H
Power supply	10.5 - 45 VDC≐ (with backlight LCD)
Output	DC 4-20 mA (2-wire)
Input specifications	Refer to 'Input Specifications'
Accuracy	± 0.3 %
Display method	PV display part: 7 segment 5 digit (character size: W4×H8 mm), Parameter display part: 14 segment 8 digit (character size: W2.6×H4.8 mm), 52 bar meter
Display range	-19,999 to 99,999
Setting method	HART-protocol (no setting key)
Response time	1 sec
Alarm	≤ 3.8 mA, > 20.5 mA / Sensor break 3.6 mA
Load	≤ (V power supply - 7.5 V) / 0.22 A
Galvanic insulation	2 kVAC~ (Input/Output)
Unit weight (Packaged)	≈ 1.2 kg (≈ 1.4 kg)

Ambient temp.	-20 to 70 °C, storage: 20 to 80 °C (no freezing or condensation)
Ambient humi.	0 to 85 %RH, storage: 0 to 85 %RH (no freezing or condensation)
Protection structure	IP67 (IEC standard)
Material	Body: Aluminum (AlDc.8S), Cover O-Ring: Buna N
Explosion class <sup>01)</sup>	Ex d IIC T6
Approval	

01) The explosion class specification is acquired and managed by KONICS.

### Input Specifications

Input type		Input range (°C)	Input range (°F)
Thermocouple	K (NiCr-Ni)	-270 to 1,372	-454 to 2,501.6
	J (Fe-CuNi)	-210 to 1,200	-346 to 2,192
	E (NiCr-CuNi)	-270 to 1,000	-454 to 1,832
	T (Cu-CuNi)	-270 to 400	-454 to 752
	B (PtRh30-PtRh6)	0 to 1,820	32 to 3,308
	R (PtRh13-Pt)	-50 to 1,768	-58 to 3,214.4
	S (PtRh10-Pt)	-50 to 1,768	-58 to 3,214.4
	N (NiCrSi-NiSi)	-270 to 1,300	-454 to 2,372
	Cu50 Ω	-50 to 150	-58 to 302
	Cu100 Ω	-50 to 150	-58 to 302
RTD	DPt100 Ω	-200 to 850	-328 to 1,562
	DPt500 Ω	-200 to 250	-328 to 482
	DPt1000 Ω	-200 to 250	-328 to 482
	Ni100 Ω	-60 to 180	-76 to 356
	Ni500 Ω	-60 to 180	-76 to 356
	Ni1000 Ω	-60 to 150	-76 to 302
Resistance transmitter	Resistance (Ω)	0 to 400 Ω	-
		0 to 2000 Ω	-
Analog	Voltage	-10 - 75 mV	-
		-100 - 100 mV	-
		-100 - 500 mV	-
		-100 - 2,000 mV	-

### Opening the Cover

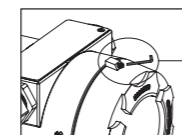

To open the cover, unscrew the M3×6L headless bolt using a 1.5 hexagon wrench and rotate the cover.

### Dimensions

Unit: mm, For the detailed drawings, follow the Autonics website.

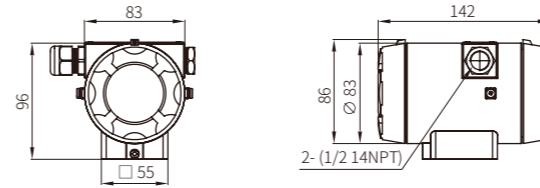

#### With bracket

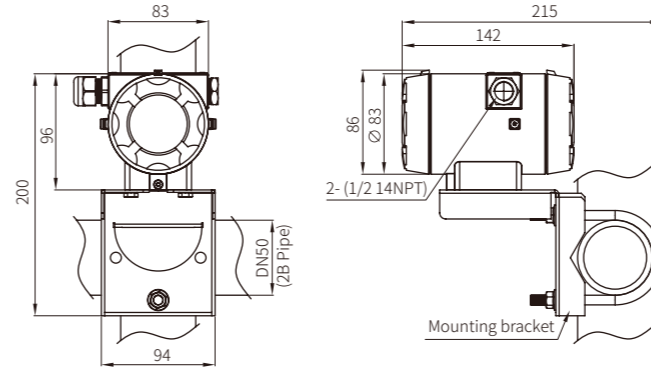

### Connections

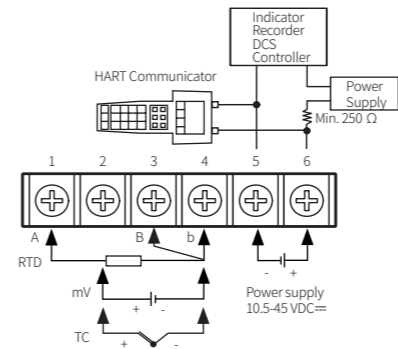

### Temperature Range Setting

Connect a HART communicator and set temperature range as follows.

- Press **[F3]** key for 3 sec.  
Select '4. PV LRV' by using **[↑]**, **[↓]** keys and press **[→]** key.
- Select '1. PV LRV' (Low temp. range) and press **[→]** key.
- Set Low temp. range and press **[ENTER]** (F4) key.
- Select '2. URV' (High temp. range) and press **[→]** key.
- Set High temp. range and press **[ENTER]** (F4) key.
- When the set temperature range is correct, press **[SEND]** (F2) key.
- Press **[OK]** (F4) key.
- Press **[OK]** (F4) key.
- Check the set temperature range.  
Press **[HOME]** (F3) key.  
HART communication will be off.

### Current Trim Setting

- Connect a HART communicator and set temperature range as follows.
  - Select '1. Device Setup' by using **[↑]**, **[↓]** keys and press **[→]** key.
  - Select '2. Diag/Service' by using **[↑]**, **[↓]** keys and press **[→]** key.
  - Select '4. D/A trim' by using **[↑]**, **[↓]** keys and press **[→]** key.
  - Press **[OK]** (F4) key.
  - Press **[OK]** (F4) key.
  - Press **[OK]** (F4) key.
  - Press **[ENTER]** (F4) key to set 4 mA display value.
  - If output display value is correct, select '1. Yes' and press **[ENTER]** (F4) key. If not, select '2. No' and press **[ENTER]** (F4) key and re-set the display value. E.g.) If output display value is 3.89mA, select 3.89 and press **[ENTER]** (F4) key.
  - Press **[OK]** (F4) key.
  - Press **[ENTER]** (F4) key to set 20 mA display value.
  - If output display value is correct, select '1. Yes' and press **[ENTER]** (F4) key. If not, select '2. No' and press **[ENTER]** (F4) key and re-set the display value.
  - Press **[OK]** (F4) key.
  - Press **[HOME]** (F3) key.
  - Press **[QUIT]** (F3) key.
  - Press **[F3]** key to quit the setting menu.

### Error

Display	Error	Troubleshooting
E r r 05	Temperature sensor A, B or all sensors are disconnected	Check the temperature sensor
E r r 06	Temperature sensor B is disconnected	
E r r 07	When PV is lower than the low-limit value of set temperature range	Check the low-limit value of the set temp. range
E r r 08	When PV is higher than the high-limit value of set temperature range	Check the high-limit value of the set temp. range