

Inductive Linear Positioning Sensors

LPD Series

INSTRUCTION MANUAL

TCD230053AE

Autonics

Thank you for choosing our Autonics product.

Read and understand the instruction manual and manual thoroughly before using the product.

For your safety, read and follow the below safety considerations before using. For your safety, read and follow the considerations written in the instruction manual, other manuals and Autonics website.

Keep this instruction manual in a place where you can find easily.

The specifications, dimensions, etc. are subject to change without notice for product improvement. Some models may be discontinued without notice.

Follow Autonics website for the latest information.

Safety Considerations

- Observe all 'Safety Considerations' for safe and proper operation to avoid hazards.
- ⚠ symbol indicates caution due to special circumstances in which hazards may occur.

⚠ Warning Failure to follow instructions may result in serious injury or death.

01. Fail-safe device must be installed when using the unit with machinery that may cause serious injury or substantial economic loss. (e.g. nuclear power control, medical equipment, ships, vehicles, railways, aircraft, combustion apparatus, safety equipment, crime/disaster prevention devices, etc.)

Failure to follow this instruction may result in personal injury, economic loss or fire.

02. Do not use the unit in the place where flammable/explosive/corrosive gas, high humidity, direct sunlight, radiant heat, vibration, impact or salinity may be present.

Failure to follow this instruction may result in explosion or fire.

03. Do not disassemble or modify the unit.

Failure to follow this instruction may result in fire.

04. Do not connect, repair, or inspect the unit while connected to a power source.

Failure to follow this instruction may result in fire.

05. Check 'Connections' before wiring.

Failure to follow this instruction may result in fire.

⚠ Caution Failure to follow instructions may result in injury or product damage.

01. Use the unit within the rated specifications.

Failure to follow this instruction may result in fire or product damage.

02. Use a dry cloth to clean the unit, and do not use water or organic solvent.

Failure to follow this instruction may result in fire.

Cautions during Use

- Follow instructions in 'Cautions during Use'. Otherwise, it may cause unexpected accidents.
- Power supply should be insulated and limited voltage/current or Class 2, SELV power supply device.
- Use the product, after about 15 min of supplying power. Temperature compensation stabilizes the device. If device stabilization is not completed, sensing performance deteriorate.
- When teaching, the [Teach-in] button axis must be pressed correctly for operation. Do not press the button with a sharp object. If the button is damaged, there may be operational or functional problems.
- Wire as short as possible and keep away from high voltage lines or power lines, to prevent surge and inductive noise. Do not use near the equipment which generates strong magnetic force or high frequency noise (transceiver, etc.). In case installing the product near the equipment which generates strong surge (motor, welding machine, etc.), use diode or varistor to remove surge.
- This unit may be used in the following environments.
 - Indoors (UL Type 1 Enclosure)
 - Altitude max. 2,000 m
 - Pollution degree 3
 - Installation category II

Cautions for Installation

■ Environment

- Install the unit correctly with the usage environment, location, and the designated specifications.
- Install no objects other than the sensing target in the detection width area. For the area, refer to the product manual.

■ Wire

- Do NOT impact with a hard object or excessive bending of the wire lead-out. It may cause damage the water resistance.
- In case of IO-Link mode, the cable length between the unit and the IO-Link Master should be under 20 m.
- Fasten the connector not to shown the thread.
- Fasten the vibration part with PTFE tape.

■ Tightening torque

- Connector - M8: ≤ 0.2 N m
M12: 0.39 to 0.49 N m
- M4 × 14 bolt (LPD-14-□-□): 0.5 N m
(LPD-103-□-□): 3 N m

■ Influence by surrounding metals

When devices are mounted on metallic panel, it must be prevented devices from being affected by any metallic object except target.

To prevent malfunction due to surrounding metal, install as follows.

• LPD-14-□-□

Maintain a metal-free area of approximately 5 mm along all sides of the aspect of the product.

If the detection object is not a steel for general structure (SS275, SM45C, etc.), attach the target (TG-LPD-T8, sold separately) to the detection object and use it.

• Unit: mm

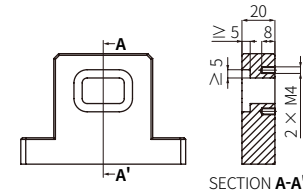

• LPD-103-□-□

Maintain a metal-free area of approximately 20 mm along all sides of the aspect of the product.

• Unit: mm

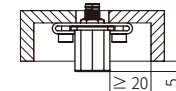

Ordering Information

This is only for reference, the actual product does not support all combinations. For selecting the specified model, follow the Autonics website.

LPD - ① - ② - ③

① Detection range

14: 14 mm
103: 103 mm

② Output

No mark: Voltage + Current
V: Voltage
C: Current
IL2: IO-Link COM2

③ Connection type

No mark: Cable type
W12: Cable M12 connector type
CM8: M8 connector type
CM12: M12 connector type

Product Components

Model	LPD-14-□-□	LPD-103-□-□
Product components	Product, Instruction manual	
M4 × 14 bolt	× 2	× 4
Bracket	-	× 2

Sold Separately

- M8 Connector cable: C□D4-□EB, C□DH4-□EB
- M12 Connector cable: C□D4-□, C□DH4-□
- Target: TG-LPD-T8

Software

Download the installation file and the manuals from the Autonics website.

■ atIOLink

atIOLink with purposes for setting, diagnosis, and maintenance of IO-Link device via IODD file is provided as the Port and Device Configuration Tool (PDCT).

- IODD (IO Device Description)

This file contains information such as manufacturer information, process data, diagnostic data, and parameter setting of a device using IO-Link communication.

By uploading the IODD file to PDCT Software, you can check the setting and communication data according to the user interface.

Download the IODD file from the Autonics website.

Dimensions

- Unit: mm, For the detailed, follow the Autonics website.

A 01)	Teach-in button
B	Indicator (green / red LED)
C	Detection object
D	Sensing part

01) For Voltage + current / Voltage / Current output model

■ LPD-14-□-□

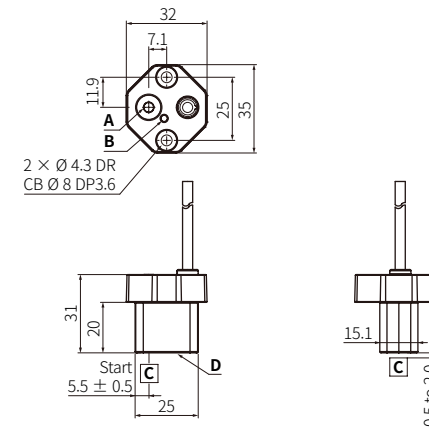

• Panel cut-out

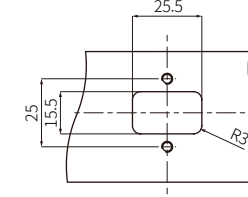

■ LPD-103-□-□

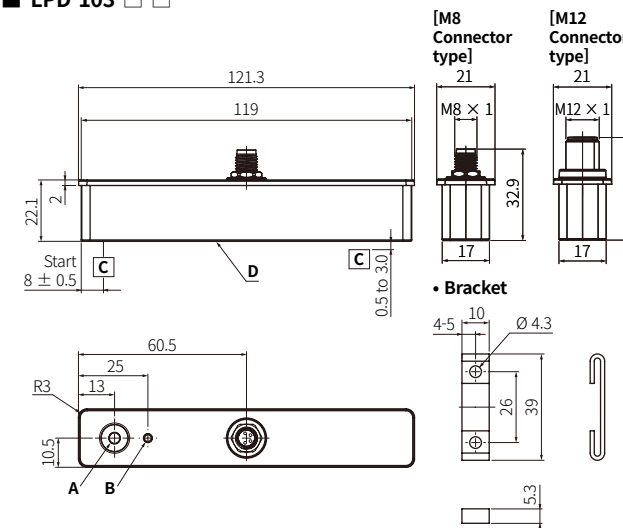

• Bracket

• Panel cut-out

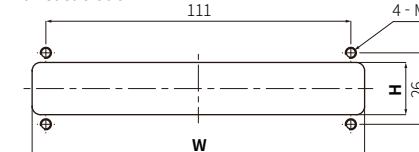

	M8	M12
H	≥ 19	
W	≥ 121	

Connections

Pin	Color	Voltage / Current output	Voltage + Current output	IO-Link output
1	Brown	VCC		
2	White	N.C	I OUT	N.C
3	Blue	GND		
4	Black	V OUT / I OUT	V OUT	C/Q

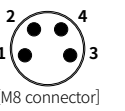

[M8 connector]



[M12 connector]

Wiring Diagram

■ LPD-14-V-□

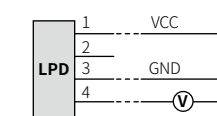

■ LPD-14-C-□

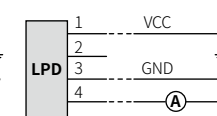

■ LPD-14-IL2-□

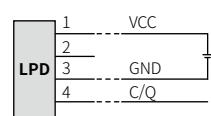

■ LPD-103-□

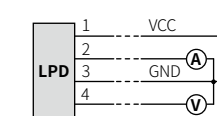

■ LPD-103-IL2-□

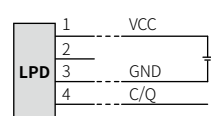

Indicator

- START, END points are based on the center of the detection object.

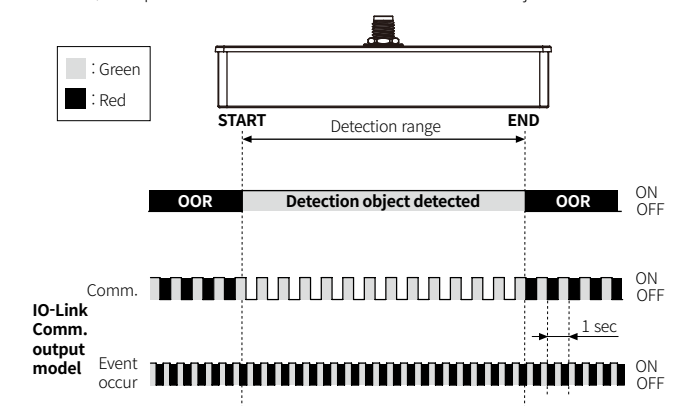

Analog Output Feature Data

■ LPD-14-V-□

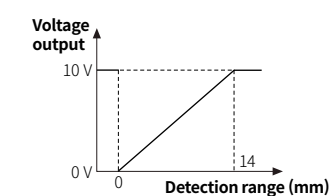

■ LPD-14-C-□

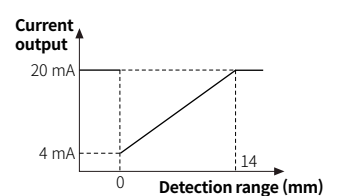

■ LPD-103-□

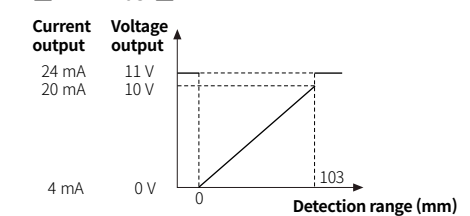

Specifications					
Model	LPD-14-V-□	LPD-14-C-□	LPD-14-IL2-□	LPD-103-□	LPD-103-IL2-□
Detection range	14 mm			103 mm	
Detection object distance	0.5 to 2.0 mm			0.5 to 3.0 mm	
Function	Positioning				
Detection type	Inductive				
Linearity	± 250 μm			± 400 μm	
Repeatability	± 80 μm				
Response time	≤ 30 ms				
Power supply	15 - 30 VDC≐, Rated voltage: 24 VDC≐				
Max. power ripple	10 % of rated voltage			10 % of rated voltage	15 % of rated voltage
Output spec.⁰¹⁾	0 - 10 VDC≐	DC 4 - 20 mA	IO-Link COM2	0 - 10 VDC≐ DC 4 - 20 mA	IO-Link COM2
OOB ⁰²⁾ output	10 VDC≐	20 mA	IO-Link COM2	11 ± 0.5 VDC≐ DC 24 ± 2.5 mA	IO-Link COM2
Load resistance	≥ 2,000 Ω	≤ 500 Ω	-	Voltage: ≥ 2,000 Ω Current: ≤ 500 Ω	-
Current consumption (no load)	≤ 20 mA			≤ 30 mA	≤ 35 mA
Insulation resistance	≥ 100 MΩ (500 VDC≐ megger)				
Dielectric strength	Between the charging part and the case: 500 VAC~ 50 / 60 Hz for 1 min				
Vibration	1.0 mm double amplitude at frequency 10 to 55 Hz in each X, Y, Z direction for 30 min.				
Shock	Half-sinus, 30 g, 11 ms (EN 60068-2-27, Shock)				
Protection circuit	Output short over current protection circuit, reverse polarity protection circuit				
Ambient temp.⁰³⁾	-25 to 70 °C, storage: -25 to 70 °C (no freezing or condensation)			-25 to 85 °C, storage: -25 to 85 °C (no freezing or condensation)	
Ambient humi.	35 to 85 %RH, storage: 35 to 85 %RH (no freezing or condensation)				
Protection rating	IP67 (IEC standard)				
Standard detection object material	Steel for general structure (SS275, SM45C, etc.).				
Material	Housing, sensing part: PBT				
Certification	CE, RoHS, REACH, IO-Link ⁰⁴⁾				

01) For more information, refer to 'Analog Output Feature Data'.

02) Out of Range. When there is no detection object within the detection range or teaching range

03) UL approved ambient temperature: 70 °C

04) It is applied to IO-Link communication output model.

Model	LPD-14-□-□		LPD-103-□-□	
Connection type	Cable type	Cable connector type	Connector type	
Connector spec.	-	M12 4-pin plug	M8 4-pin plug	M12 4-pin plug
Cable spec.	Ø 4 mm, 4-wire (oil resistant PVC)	Ø 4 mm, 4-wire (oil resistant PVC)		
Cable length	2 m	300 mm		
Wire spec.	AWG 23 (0.08 mm, 60-core)	AWG 23 (0.08 mm, 60-core)		
Insulator diameter	Ø 1.28 mm	Ø 1.28 mm		
Unit weight (package)	≈ 67.74 g (≈ 76.7 g)	≈ 33.06 g (≈ 42.6 g)	≈ 49.4 g (≈ 74.8 g)	≈ 53.5 g (≈ 79.0 g)

Communication Interface

IO-Link

Version	Ver. 1.1
Class	Class A
Baud rate	COM 2 (38.4 kbps)
Min. cycle time	2.3 ms
Data length	PD: 2 byte, OD: 1 byte (M-sequence: TYPE_2_2)
Vendor ID	899 (0x383)

Parameter Index

It is applied to IO-Link communication output model.

Process data

- The current data value is displayed in real time.

	Bit 7	Bit 6	Bit 5	Bit 4	Bit 3	Bit 2	Bit 1	Bit 0	
Byte0 (PD0)	Distance Data								
Byte1 (PD1)	Distance Data				-	-	-	OOR Status Flag	

Parameter	Description	Setting range	Type
Distance Data	Outputs the position of the detected object as specific 12 bit.	0 to 4,095	UInteger
OOR Status Flag	Indicates whether OOR status is present.	0: OFF 1: ON	Boolean

Identification menu

- The device's manufacturer information and device information is displayed. It includes additionally information of companies and devices from the IO-Link standard.

Index	hex.	dec.	Parameter	Description	Type	Access
0x10	16		Vendor Name	Manufacturer name	String	RO
0x11	17		Vendor Text	Manufacturer description	String	RO
0x12	18		Product Name	Product name	String	RO
0x13	19		Product ID	Product ID	String	RO
0x14	20		Product Text	Product description	String	RO
0x15	21		Serial Number	Product serial number	String	RO
0x16	22		H/W Version	Hardware version	String	RO
0x17	23		F/W Version	Firmware version	String	RO
0x18	24		Application specific tag	Application program tag	String	RW

Parameter menu

- Product settings such as reset and lock can be changed according to the user environment.

Index	hex.	dec.	Subindex	Parameter	Description	Setting range	Default	Type	Access	
0x2	2		-	System Command	Factory default reset	130: Restore factory setting	-	UInteger	WO	
0xC	12		-	Device Access Locks	Device	Device lock settings	-	Record	RW	
			2		Data Storage	Data Storage function lock settings	0: unlock, 1: lock	0	Boolean	RW
0x41	65		-	Teaching Position Data	Position	START, END point setting value	-	UInteger	RO	
			1		START	START point teaching position	15 to 4 bit: position	0	UInteger	RO
			2		END	END point teaching position	15 to 4 bit: position	0	UInteger	RO
0x42	66		-	Teaching Setup	Teaching Setup	0: Idle, 1: setting start, 2: START point setting, 3: END point setting, 4: setting complete, 5: reset	0	Record	RW	
0x43	67		-	Teaching Setup Status	Teaching setting status	0: Idle, 1: setting start, 2: START point setting, 3: END point setting, 4: setting complete, 5: reset, 6: error	0	UInteger	RO	
0x48	72		-	User Customize Operating Time	Operating time alarm setting	1 to 13,107 hour	13,107	UInteger	RW	

Diagnosis menu

- The information about problems encountered during device operation is displayed.

Index	hex.	dec.	Parameter	Description	Type	Access
0x25	37		Detailed Device Status	Product Detailed Status	Record	RO
0x28	40		Process Data Input	Last detected object position	UInteger	RO
0x47	71		Operating Hours	Device operating time	UInteger	RO

Events

- When an event occurs, the red-green indicator lights alternately flash.

Code	hex.	dec.	Event	Description	Type
0x1801	6145		Load Short Circuit or Output	Output short over current warning	Warning
0x1802	6146		Transceiver Overheating	Transceiver overheating warning	
0x1804	6148		Supply Under Voltage	Low voltage detection warning	
0x1805	6149		Operation Time Elapsed	Operation time alarm warning	
0x1807	6151		EEPROM Error	EEPROM error warning	
0x1806	6150		Parameter Setting Error	Parameter error	

Teaching

Set the detection range through teaching. It will be applied immediately once the teaching settings are completed.

- START, END positions can be set in forward / reverse direction.
- Teach so that the distance between START and END points satisfies the following. Otherwise, a teaching error occurs and set from '2. START point teaching'.
 - LPD-14-□-□ : > 7 mm
 - LPD-103-□-□ : > 51.5 mm

Voltage / Current / Voltage + Current output model

Teach using the [Teach-in] button. Press the button axis correctly to proceed with the teaching operation.

- If there is no [Teach-in] button input for 120 seconds after '1. Entering teaching mode', the settings are not saved and returns to RUN mode.

Teaching

No.	Operation	
1	Entering teaching mode	In RUN mode, place the detection object within the detection range where the green indicator turns ON. Press the [Teach-in] button for 2 sec. The green indicator flashes (1 Hz).
2	START point teaching	Place the detection object at the START point. Press the [Teach-in] button once. The green indicator flashes (2 Hz).
3	END point teaching ⁰¹⁾	Place the detection object at the END point. Press the [Teach-in] button once. Save the teaching position value and return to RUN mode.

01) In case of a teaching error, the red indicator flashes (2 Hz).

Teaching reset

No.	Operation	
1	Entering teaching mode	In RUN mode, place the detection object within the detection range where the green indicator turns ON.
2	Reset	Press the [Teach-in] button for 10 sec. The green indicator flashes (3 Hz) for approximately 5 sec.
3	Reset complete	The green indicator turns ON and operates in RUN mode.

IO-Link Communication output model

Teach using software atIOlink parameter settings.

- If there is no input to Index 66 (Teaching Setup) for 120 seconds after '1. Entering teaching mode', the value of Index 67 (Teaching Setup Status) becomes 4 (setting complete). The settings are not saved and returns to RUN mode.

Teaching

No.	Operation	
1	Entering teaching mode	In RUN mode, place the detection object within the detection range where the green indicator flashes. Write 1 (setting start) at Index 66. Confirm that the Index 67 value is 1.
2	START point teaching	Place the detection object at the START point. Write 2 (START point teaching) at Index 66. Confirm that the Index 67 value is 2.
3	END point teaching ⁰¹⁾	Place the detection object at the END point. Write 3 (END point teaching) at Index 66. Confirm that the Index 67 value is 3.
4	Return to RUN mode	Write 4 (setting complete) at Index 66. Confirm that the Index 67 value is 4.

01) In case of a teaching error, 6 (error) is displayed in Index 67.

Teaching reset

No.	Operation	
1	Entering teaching mode	In RUN mode, place the detection object within the detection range where the green indicator flashes. Write 1 (setting start) at Index 66. Confirm that the Index 67 value is 1.
2	Reset	Write 5 (reset) at Index 66. Confirm that the Index 67 value is 5.